

AVIMI200 Specification Sheet



Technical Details

Construction	Galvanised Steel Casing
Rating	220-240V ~50Hz~AC 157W
IP Rating	IP44
Class	Class I
Motor	Single-phase External Rotor Motor with centrifugal impeller with backward curved blades. high-efficient motor with low energy demand on pre-oiled bearings Overheating protection by built-in thermal switches
Operating Temperature	-25°C to 55°C
Approvals	CE, ErP 2018
Warranty	5 Years Exchange
Country of Origin	UK
Manufacturer	Addvent

Performance Details

AVIMI200	m ³ /hr	l/s	dB(A) @ 3m	Power(W)
	1000	278	50	157

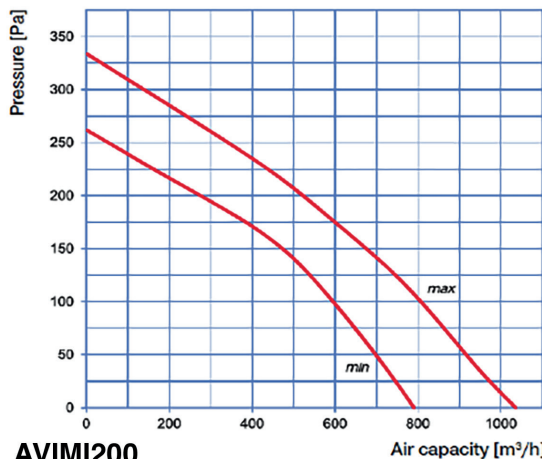

AVIMI200

Sound-power level	Gen	Octave-frequency band [Hz]							
		63	125	250	500	1000	2000	4000	8000
L _{WA} to inlet, [dBA]	62	26	38	51	57	58	55	52	48
L _{WA} to outlet, [dBA]	65	28	42	48	62	60	62	50	44
L _{WA} to environment, [dBA]	45	22	30	31	38	41	42	29	22

Product Description

AVIMI200 Metal In-Duct Fan

Key Features

- Duct diameters 200mm
- Aerodynamically designed casing
- Can be connected to a fan speed regulator or control system
- Can be used for supply and extract air
- Dynamically balanced Turbine
- Casing made of low-flammable polypropylene
- Designed to fit all standard duct sizes
- Can be installed anywhere in a ducted ventilation systems. Equipped with thermal overload protection with automatic restart. Highly efficient range of low noise extractor fans
- 5 Year warranty

Models

Model No.	Product Description
AVIMI200	200mm Metal In-Duct Fan

Dimensions

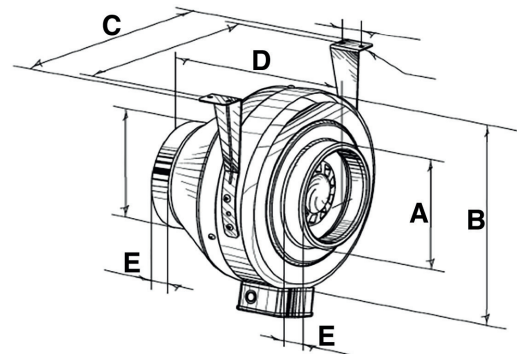

B	BI	ØD	ØDI	L	LI	L2	L3
340	380	198	332	200	25	29	40

Additional Information

- Mounting feet on Fan to allow installation to Floor, Walls and Ceiling
- Ideal solution for limited spaces due to the compact design Smooth speed control is possible with an additional speed controller
- External Airtight terminal block on casing for power supply



Tel: +44 (0)117 923 5375

Email: enquiries@addvent.co.uk