

AVHRU3N Specification Sheet



Key Features

- Powered heat recovery module for smaller commercial applications
- Up to 70% heat recovery
- 150mm duct connection
- Extremely quiet on low speeds
- Low power consumption
- Washable heat exchanger
- Pre-wired to a flexible cable

Dimensions

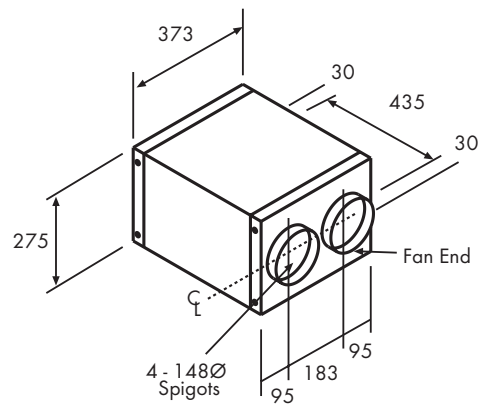

Performance Details

Motor Speed	1	2	3
Voltage	140	160	240
Watts	51.5	60	110
Volume l/s (FID) Supply	48.3	55.8	70.3
Extract	241	286	371

AVHRU3N to be used with a 150VA Transformer for maximum controllability.

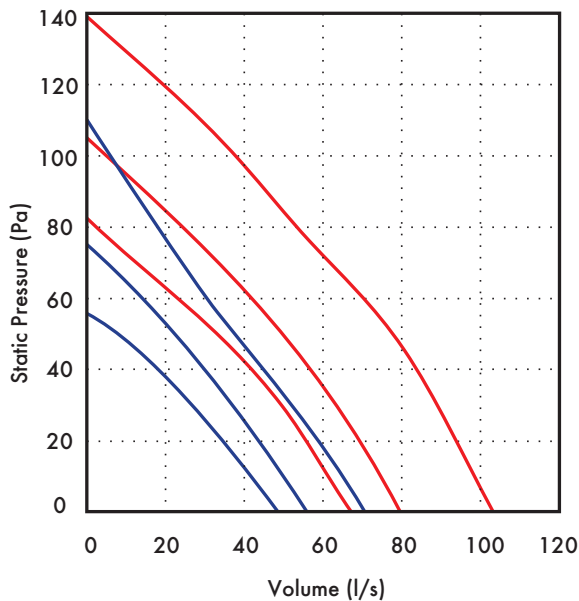

- 240V Supply
- 160V Supply
- 140V Supply
- 240V Extract
- 160V Extract
- 140V Extract

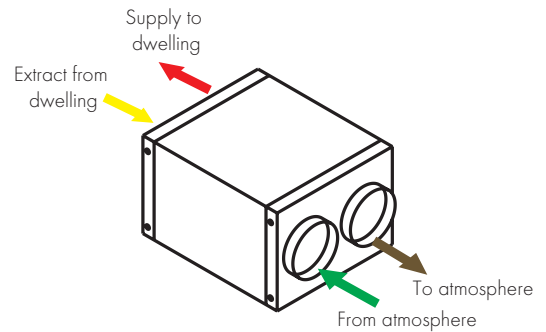

Weight	15.5kg fan box, 5kg controller
--------	--------------------------------

SEC Class Rating

Model	SEC Class	SEC Class (inc. LDC)
AVHRU3N	C	B



Tel: **+44 (0)117 923 5375**
 Email: enquiries@addvent.co.uk