

Addvent 150mm Compact Inline Mixed Flow Fan Specification Sheet

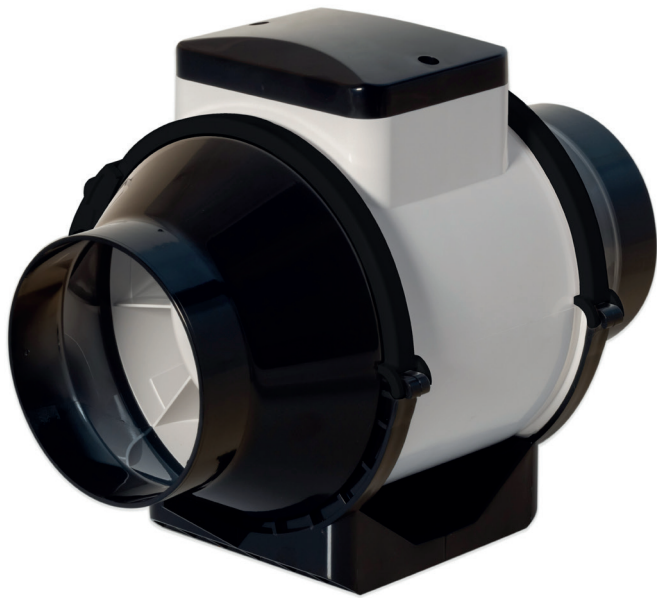

Key Features

- Compact low-profile design
- Designed for applications that require high air flows, with low relative noise
- Part F Compliant
- Mountable in a variety of applications and positions
- For use with either rigid or flexible ducting
- High quality ball bearing, long life motors and continuously rated
- 2 speed settings
- Easy installation and maintenance with removable central section

Dimensions

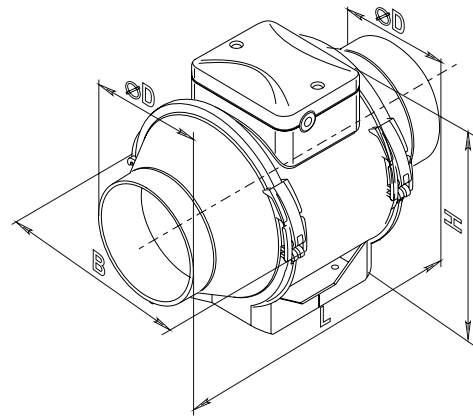

Product	ØD	B	H	L
AVCIMFI50SC	146	223	250	295
AVCIMFI50TC	146	223	250	295

Technical Details

Construction	Low-Flammable Polypropylene
Rating	230V
IP Rating	IPX4
Max Operating Temperature	40°C
Class	Double Insulated
Motor	2-speed German Ball Bearing motor AC
Approvals	UKCA, CE
Warranty	5 Years Exchange
Country of Origin	UK
Manufacturer	Addvent

Options

Model Modifications	S	T
Standard	●	-
Timer	-	●

Standard (S)	Standard Model for Remote Switching
Timer (T)	Adjustable from 2 to 30 minutes

Models

Model No.	Product Description
AVCIMFI50SC	150mm Compact Inline Mixed Flow Fan Standard Model
AVCIMFI50TC	150mm Compact Inline Mixed Flow Fan with Timer Model

LinkedIn



Tel: +44 (0)117 938 6402
Email: enquiries@addvent.co.uk

Performance Details

Product	Speeds	Airflow		Power (W)	SFP (W/l/s)*	Sound Level dB(A) @3m
		l/s*	m ³ / hr*			
AVCIMF150SC	High	145	525	60	0.413	44
	Low	114	409	30	0.263	33
AVCIMF150TC	High	145	525	60	0.413	44
	Low	114	409	30	0.263	33

*± 1%

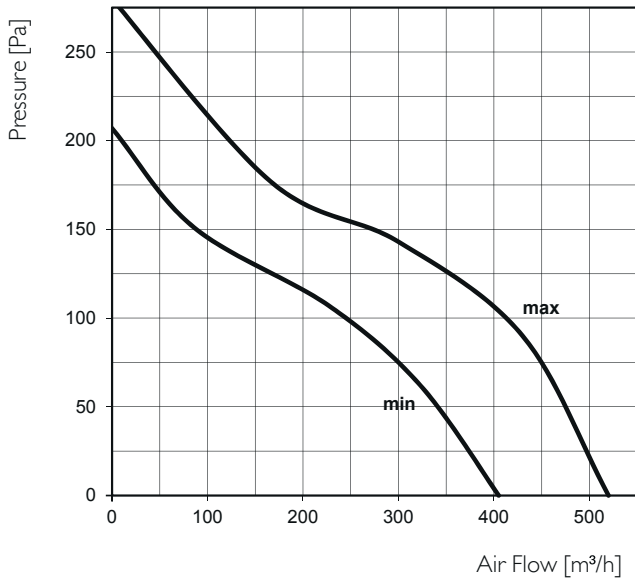

Installation Information

Inline Mountable

Additional Information

Weight (kg) 2.65

