

# **AVAC9000**

## **Portable Air Conditioner**

### **Installation Instructions**

#### **User Guide**



### **IMPORTANT SAFEGUARDS**

**WHEN USING ANY ELECTRICAL APPLIANCE, BASIC SAFETY PRECAUTIONS SHOULD ALWAYS BE FOLLOWED.**

**PLEASE READ ALL INSTRUCTIONS CAREFULLY AND RETAIN FOR FUTURE REFERENCE**

**ADDVENT**

## BEFORE USE



- These symbols on your device mean:
- This appliance is filled with Propane gas R290. Follow strictly the manufacturer's instruction concerning use and repairs!
- Before using the machine, read carefully the entire instruction manual.
- Do not install, operate or store the device in a room smaller than 9 m<sup>2</sup>.

## Safety Instructions

## WARNING

- This appliance can be used by children aged from 8 years and above and persons with reduced physical, sensory or mental capabilities or lack of experience and knowledge if they have been given supervision or instruction concerning use of the appliance in a safe way and understand the hazards involved.
- Cleaning and user maintenance shall not be made by children without supervision.
- Children of less than 3 years old should be kept away unless continuously supervised.
- Children aged from 3 years and less than 8 years shall only switch on/off the appliance provided that it has been placed or installed in its intended normal operating position and they have been given supervision or instruction concerning use of the appliance in a safe way and understand the hazards involved. Children aged from 3 years and less than 8 years shall not plug in, regulate and clean the appliance or perform user maintenance.
- Never use this appliance for anything other than its intended purpose.
- Your air conditioner is designed to be used in a house, office and similar conditions and should not be used for any other purpose.
- If the supply cord is damaged, it must be replaced by a suitably qualified person in order to avoid a hazard.
- Always keep the unit in an upright position to avoid damage to the cooling system.
- Be sure that the air inlets and outlets are not blocked or covered.
- Don't put any object into the air inlet or outlet of the unit.
- In order to avoid overheating, do not cover the unit while it is plugged in or in-use.
- Never connect the unit to a defective socket.
- Never locate the appliance immediately below a socket-outlet.
- Never unplug the air conditioner while it is operating. This could damage the electronic circuits.
- Leave at least 300mm space around the unit.
- To avoid tripping the circuit, do not use an extension cord for this unit.

- To turn on your unit, insert the plug into the socket and press the power button.
- Do not bend or crush the exhaust hose.
- Do not place the power cord under a carpet.
- This appliance is for ordinary indoor use. Never use the appliance in the immediate surroundings of a bath, a shower, a swimming pool or a greenhouse.
- Keep the appliance in the vertical position during transportation. After unpacking, place the unit upright to allow the refrigerant to stabilise, and wait 3 hours before use.

**Any damage resulting from failure to comply with these instructions is excluded from the warranty. Do not install and use your air conditioner before completely reading these instructions.**

**⚠ CAUTION:** *Dispose of packaging material safely according to local regulations*

## **SAFETY RELATING TO REFRIGERANT R290**

- Read these warnings carefully.
- This appliance contains the refrigerant R290. R290 is a refrigerant that complies with the relevant European Directives. Never perforate the refrigerant circuit. R290 is flammable (GWP3)!
- Do not use means to accelerate the defrosting process or to clean, other than those recommended by the manufacturer.
- The appliance shall be stored in a room without continuously operating ignition sources (for example: open flames, an operating gas appliance or an operating electric heater).
- Do not pierce or burn any of the components of the cooling circuit of the unit. Do not set light to the unit.
- The appliance shall be stored so as to prevent mechanical damage from occurring.
- Appliance should be installed, operated and stored in a room with a floor area larger than 9 m<sup>2</sup>.
- Be aware that the refrigerants may not contain an odour, which means you cannot smell leaks..
- Compliance with national gas regulations shall be observed.
- Keep ventilation openings clear of obstruction.
- A warning that the appliance shall be stored in a well-ventilated area where the room size corresponds to the room area as specified for operation.
- Any person who is involved with working on or breaking into a refrigerant circuit should hold a current valid certificate from an industry-accredited assessment authority, which authorises their competence to handle refrigerants safely in accordance with an industry recognised assessment specification.
- Servicing shall only be performed on the grounds as recommended by the equipment manufacturer. Maintenance and repair requiring the assistance of other skilled personnel shall be carried out under the supervision of the person competent in the use of flammable refrigerants.

## Components

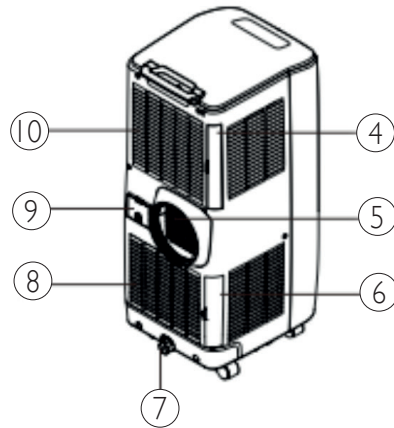
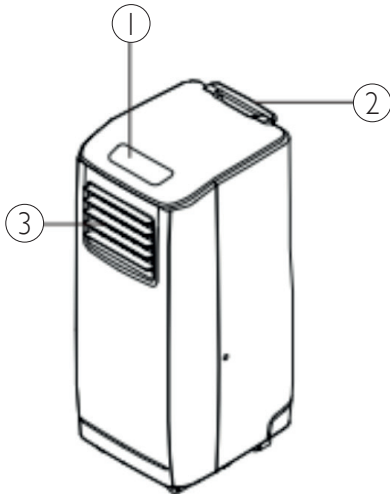

- |                    |                                     |                 |
|--------------------|-------------------------------------|-----------------|
| 1. Control panel   | 5. Exhaust air outlet               | 8. Air inlet    |
| 2. Carrying handle | 6. Air filter                       | 9. Cord storage |
| 3. Air outlet      | 7. Water stopper/<br>drainage point | 10. Air inlet   |
| 4. Air filter      |                                     |                 |

## Accessories

11. Exhaust hose
12. Flat Type Adaptor - for insertion over hose & connected with PVC window kit (or into hole in the wall/window).
13. Inward adaptor (connected unit & exhaust hose)
14. PVC Window Kit 1 - for filling the open window space
15. PVC Window Kit 2 - for filling the open window space
16. PVC Window Kit 3 - for filling the open window space and with hole for connection to exhaust hose.
17. Drain tube for continuous drainage
18. Active carbon filter
19. Remote control

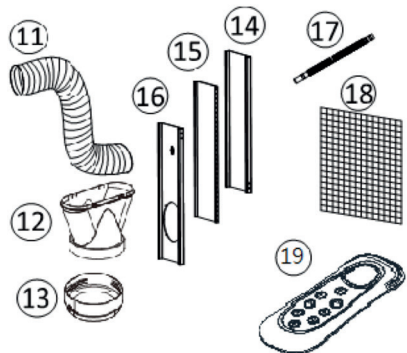

## Installation

Before using your air conditioner, you will need to install the exhaust hose so that the heat (hot air) from the appliance are released onto an outside, open-air area.

To install the exhaust hose, feed the end of the hose through any available window and secure it into place using the included adapter. Ensure the distance between the unit and the window is at least 50cm.

To seal the gap around the adapter, you may utilize the extendable slides (supplied along with the appliance) as below:

- Using the extendable slides

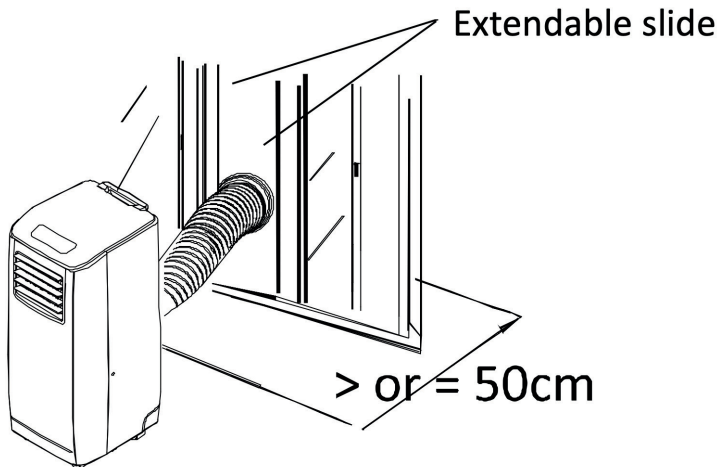

1. Offer the extendable slides to the window gap and adjust the length as you need.
2. Feed exhaust hose through the slide and slide window across so that spacer is held securely. This technique may also be used for sash windows.
3. **Note!** Take care to maintain protection against intruders

## Mounting of the exhaust hose

- Use only the hose provided and attach exhaust hose to the back of the air conditioner.

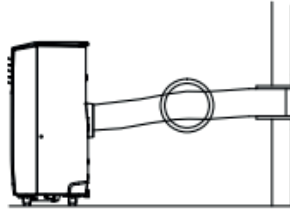

FIG. 7

- Avoid kinks and bends in the exhaust hose as this will cause expelled moist air to build up causing the unit to overheat and shut down. Fig 7 & 8 show correct position.

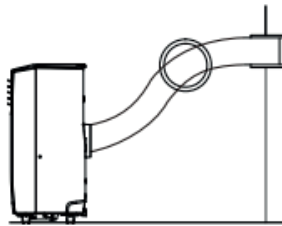

FIG. 8

- The hose may be extended from 300mm to 1500mm but for maximum efficiency use the shortest length possible.

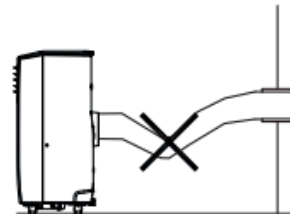

FIG. 9

### **WARNING!**

The length of the exhaust hose is specially designed according to the specification of this product. Do not replace or extend it with an alternative hose as this could cause the unit to malfunction.

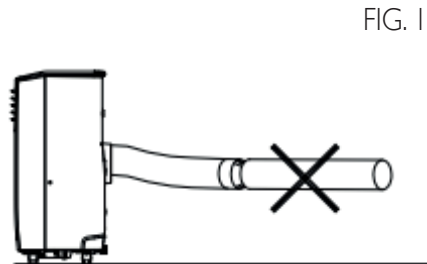

FIG. 10



## Installation of the carbon filter

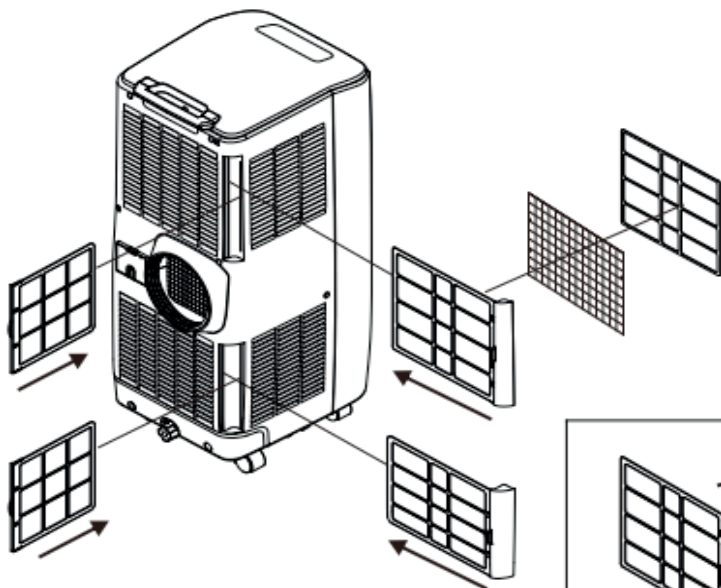

FIG. 11

1. Remove the filter frame from the unit.
2. Remove the active carbon filter from its plastic bag.
3. Insert the active carbon filter into the back of the unit.
4. Re-fit the filter frame inside the unit.

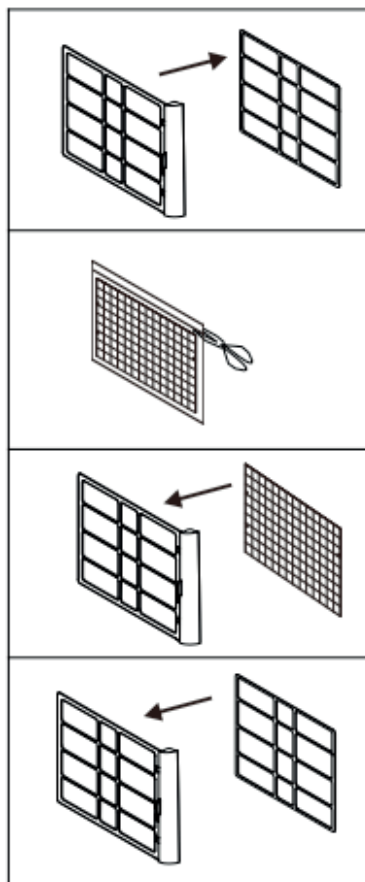

FIG. 12

## Operation

### Control panel

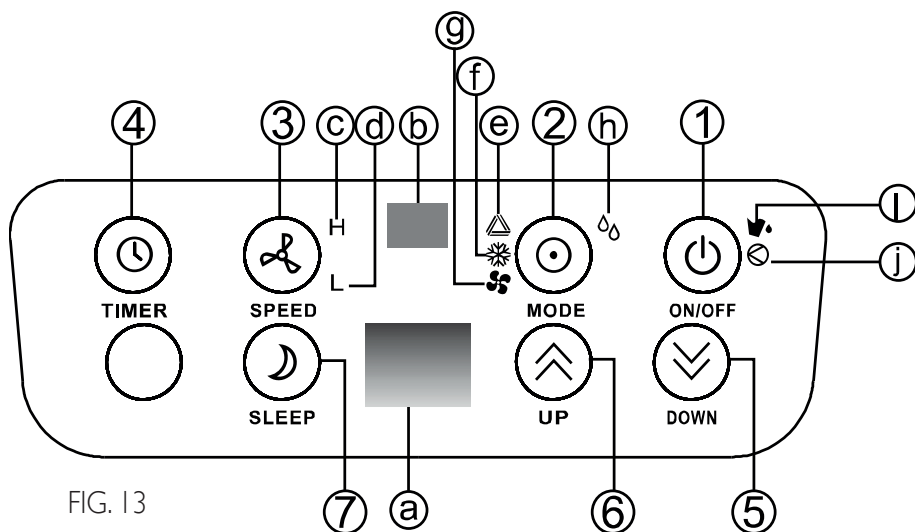

FIG. 13

1. ON/OFF (power) button
2. Mode (function) option button
3. Speed (ventilation) button
4. "Timer" button
5. "Temperature down" button
6. "Temperature up" button
7. "Sleep" button
- a. Display window
- b. Receiver for remote control
- c. High ventilation indicator
- d. Low ventilation indicator
- e. Automatic mode indicator
- f. Cooling mode indicator
- g. Fan mode indicator
- h. DEHUMIDIFY (DRY) mode indicator
- i. "Full Water" indicator
- j. Indicator for compressor operation

### Adjust the air vent

Before using the unit, please open the horizontal louvers. Adjust the louvers to your desired direction.

## Turning ON/OFF

1. Press ON/OFF button, the unit will start in AUTO (automatic) mode.

### Automatic mode

In automatic mode, the unit can cool or ventilate depending on ambient temperature and setpoint adjustment. The unit is preset as follows:

If ambient temperature is above 23°C the unit is in automatic cooling mode and is running according to the setpoint (Default setting 24°C). During this operation, the indicators (LED) for AUTO & COOLING MODE illuminate in green.

If the ambient temperature is less than or equal to ( $\leq$ ) 23°C, the unit is in automatic ventilation mode. The indicators (LED) for AUTO & FAN MODE illuminate in green.

Remark : For default setpoint 24°C, the unit starts to cool at 28°C (Setpoint + 4°C), when it cools down to 26°C (setpoint +2°C, it will then switch back to ventilation mode.

2. The display window also shows the ambient room temperature from 0°C to 50°C.

3. To turn the unit off, press ON/OFF button again.

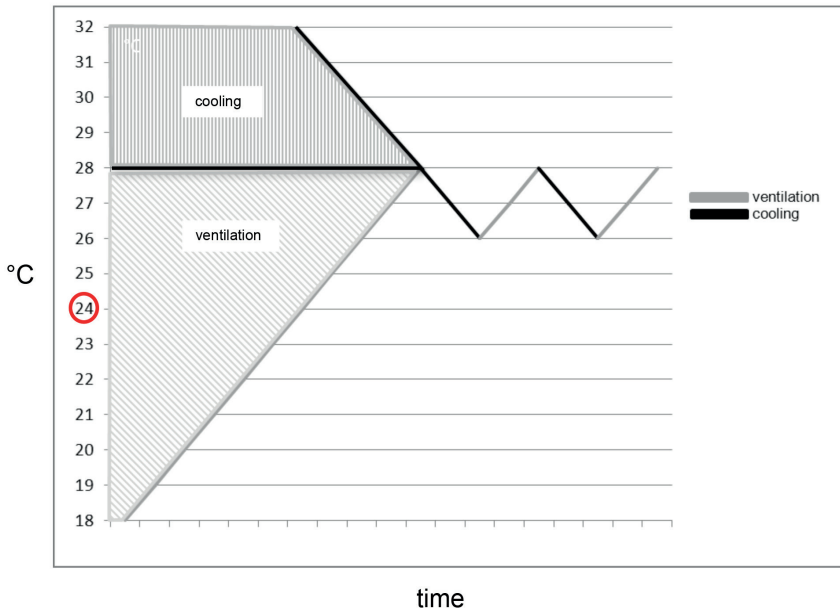

### **Setting mode/function**

Press MODE button to select required working mode: automatic, cooling, fan or dehumidify. The indicator of your selected mode is displayed.

### **Setting temperature**

1. Press 'Temperature up' or 'Temperature down' button to regulate the temperature desired.
2. The display window will show the temperature set as you press the 'Temperature up' or 'Temperature down' button. Otherwise, it will always show the ambient temperature.

### **Setting ventilation speed**

1. Press SPEED button to choose the ventilation speed desired, high or low. The indicator for high or low ventilation will illuminate at the same time.
2. If the unit is in AUTO mode, it will choose the ventilation speed automatically according to the ambient temperature (the related indicators will illuminate), at this time, the speed switch is invalid.

### **Setting timer**

1. Press TIMER button to set the operating hours desired (1 to 24 hours, the timer indicator will illuminate). When the set time has been reached, the machine will turn off automatically. The display window will show the hour(s) set as the TIMER button is pressed. If the timer button is not pressed, the unit will work continuously.
2. By pressing the timer but without turning on the other functions, you can PRE-SET the time for the machine to operate. For example, if you press the timer to '2', the unit will work automatically after 2 hours.

### **Sleep function**

1. In cooling mode, by pressing the SLEEP button, the set temperature will increase 1°C (2°F) at the 1st hour; another 1°C (2°F) at the second hour; then remains at that temperature.
2. In sleep mode, the ventilation will keep at low speed. Re-press the SLEEP button, the setting temperature and ventilation speed will return to the pre-selected one.

3. The unit will shut down automatically after the SLEEP function has been running for 12 hours.
4. Please note, the sleep function is not available while the machine is working in AUTO, FAN (ventilation) or DEHUMIDIFICATION mode.
5. When the machine is in the Sleep function, the Fan Speed is set at LOW speed.

### **Dehumidify (DRY) mode**

In dehumidify (DRY) mode, the temperature cannot be adjusted, the ventilation will fix at low speed. When the unit is operating in Dehumidify (DRY) mode, humidity extracted from the air is collected in an internal tank. If the tank reaches full, the compressor and motor cut out automatically. At the same time, the "Water Full" indicator illuminates. An alarm will also sound. When the tank is full, drain the water as shown on page 12.

You may also use the unit without having to empty the tank so often by using "continuous drainage", please also refer to page 12.

### **Self-diagnosis**

This machine is equipped with a self-diagnosis function. If a fault develops, the display window will display "E1" or "E2". At this time, please contact Addvent (0117 9235375).

All the above functions can also be performed with the supplied remote control.

The remote control requires 2pcs AAA batteries to operate (not included).



FIG. 14

### **Important**

1. To prolong the compressor's life, after turning off the unit, please wait for 3 minutes (at least) before turning back on.
2. The cooling system will switch off if the ambient temperature is lower than the set one. The ventilation, however, keeps working on the set level. If the ambient temperature rises above the selected level, the cooling will return to operation.

## Drainage

During the process of cooling, some water will be extracted from the air into the unit.

If the reservoir is full, both the compressor and motor will stop and the unit will make an audible sound (you can press any button to stop the audible sound). The W.F. indicator will also flash.

Please empty the water by one of the following methods:

1. Turn off the air conditioner and avoid moving it when full.
2. Position a container (a water tray for example) underneath the drain hole.
3. Remove the drain knob & rubber plug from the drain hole and allow the water to drain out.
4. When the container is almost full, replace the rubber plug in the drain hole and empty the water tray.
5. Repeat until the unit is emptied.
6. Replace the rubber plug and tighten the drain knob firmly.
7. Switch on the unit - the water full or compressor operating indicator should not be flashing.

If you wish to operate the unit without the need to empty the water tank, please:

- Remove the drain knob and rubber plug and retain for future use.
- Connect the drain tube supplied to the water outlet as shown and locate the other end into a drain.

FIG. 15

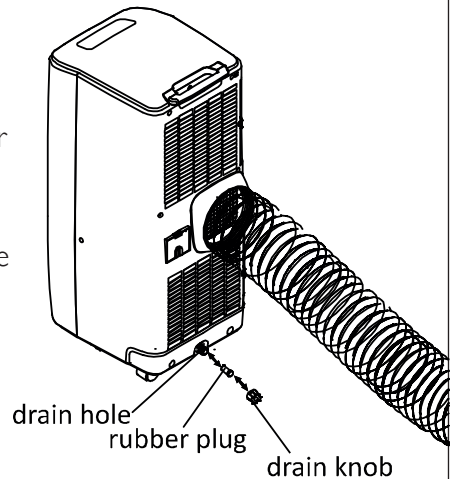
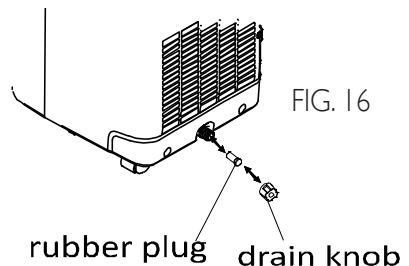

FIG. 16



- The drain tube may be extended by adding an extension tube and using a suitable connector.

Please note

1. The drain must be at or below the outlet level.
2. Flashing 'full water' indicator will not function in this mode of drainage.
3. If you want to extend the water tube, you can connect it with another tube (OD: 18mm)

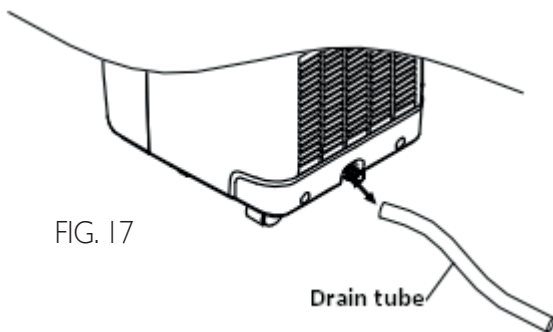

FIG. 17

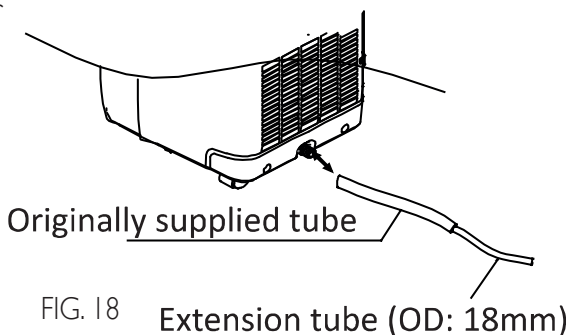

FIG. 18

Extension tube (OD: 18mm)

## Maintenance

Always unplug the air conditioner from the mains before cleaning.  
To maximize the efficiency of the air conditioner, clean regularly.

### Cleaning the housing

Use a soft, damp cloth to wipe the body clean.

Never use aggressive chemicals, gasoline, detergents, chemically treated cloths, or other cleansing solutions.

### Cleaning the filter

Use a vacuum cleaner or tap the filter lightly to remove loose dust and dirt from the filters and then rinse thoroughly under running water (no hotter than 40°C).

Dry thoroughly before replacing.

Important: Never operate the unit without the filters.

End of season storage

- Drain any water in the unit before completely operating the unit on ventilation only mode for a few hours, to thoroughly dry the inside.
- Clean or change the filter.
- Unplug and store the power cord.
- Replace in the original carton or cover for storage.



## Fault Check List

The air conditioner does not run.

- Is the air conditioner plugged in?
- Is there a power failure?
- Is the 'full water' indicator flashing?
- Is the room temperature below the set temperature?

The air conditioner does not run efficiently.

- Is the filter dirty, contaminated?
- Is the air intake or output blocked?
- Is the room temperature below the selected temperature?
- Are too many windows or doors open?

Excessive noise.

- Is the machine positioned unevenly so as to create vibration?
- Is the floor underneath the machine uneven?

The Air Conditioner compressor doesn't run.

- It is possible the overheat protection for the compressor is on. Please wait for the temperature to drop.

Never try to repair or dismantle the unit yourself.

## Specification

Model no.	AVAC9000
Power supply	220-240V~, 50Hz
Cooling capacity	9000BTU/ 2.6KW
Power/Ampere consumption	1000W/4.5A
Dehumidify capacity	24 L/day
Air Volume (max. speed)	360m <sup>3</sup> /h
Compressor	rotary
Refrigerant	R290
Fan speed	2
Timer	1~24 hours
Working temperature	18°C- 32°C
Exhaust hose	Ø 150 × 1500 mm
N.W.	22 kg
Product size (W x D x H)	317 × 402 × 770 mm



*Waste electrical products should not be disposed of with household waste. Please recycle where facilities exist. Check with your local authority or retailer for recycling advice.*

**ADDVENT**

Telephone: **0117 923 5375** Fax: **0117 982 1554**  
Unit 12, Access 18, Bristol BS11 8HT  
[www.addvent.co.uk](http://www.addvent.co.uk)

ISSUE 2/1118