

AVHR300 Specification Sheet



Key Features

- ErP Compliant
- Up to 98% heat recovery
- Supplied with F8 pollen filter and 2 x G4 filters
- Air flow up to 300m³/h
- 3 speed operation
- Integrated control panel
- Wall-mount installation
- Filter check reminder
- Simple component access panel
- Summer thermal bypass
- Automatic frost protection

Technical Details

Efficiency	max 98%
Heat exchanger	counter flow enthalpy membrane type
Motor	240V 50Hz AC with manual reset and thermal overload protection
Fan	dynamically balanced mixed-flow type
Spigots	4 x 125mmØ tapered
Filter	optional pollen filters available
Condenser drain	2 x 22mmØ
Construction	black EPP
Dimensions	893h x 590w x 316d
Weight	13kg
Country of Origin	UK
Manufacturer	Addvent

Performance Details

Exhaust Terminal Configuration	Air Flow Rate (l/s)	Specific Fanpower (W/l/s)	Heat Recovery Efficiency %
Kitchen + 1 additional wet room	21	0.61	98
Kitchen + 2 additional wet rooms	29	0.80	96
Kitchen + 3 additional wet rooms	37	1.00	94
Kitchen + 4 additional wet rooms	45	1.20	92
Kitchen + 5 additional wet rooms	53	1.40	91

* Energy Saving Trust Best Practice Performance Compliant

Product Layout

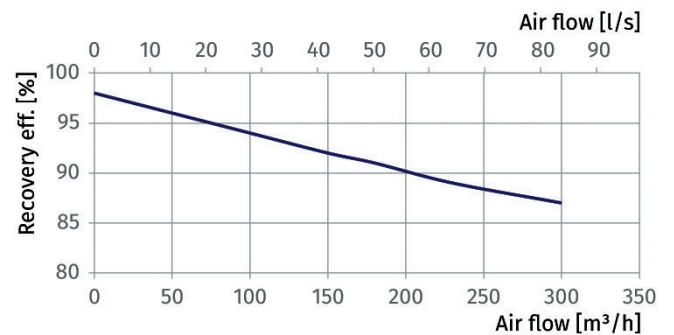
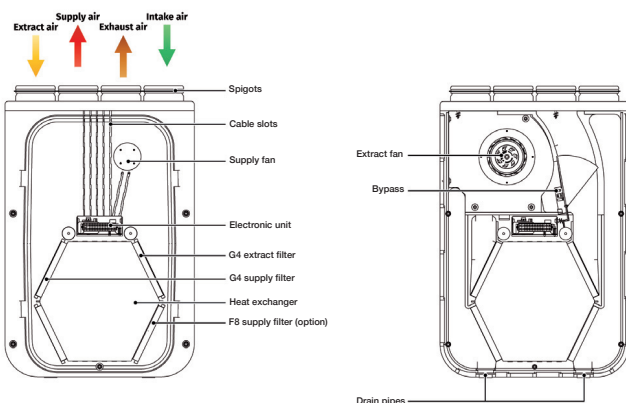

Tel: **+44 (0)117 923 5375**
 Email: enquiries@addvent.co.uk